

**TELEDYNE  
RELAYS**

A Teledyne Technologies Company

**CENTIGRID®  
ESTABLISHED RELIABILITY  
RELAYS  
DPDT**

**SERIES  
114**

SERIES DESIGNATION	RELAY TYPE
114	DPDT basic relay
114D	DPDT relay with internal diode for coil transient suppression
114DD	DPDT relay with internal diodes for coil transient suppression and polarity reversal protection

**INTERNAL CONSTRUCTION**

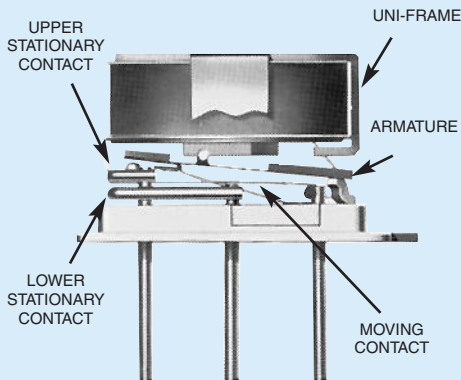

**DESCRIPTION**

The Series 114 Centigrid® relay is an ultraminiature, hermetically sealed, armature relay. Its low profile height (.275") and .100" grid spaced terminals, which precludes the need for spreader pads, make it ideal for applications where extreme packaging density and/or close PC board spacing are required.

The basic design and internal construction are similar to the standard Teledyne DPDT TO-5 relay (e.g., Series 412). The following unique construction features and manufacturing techniques provide overall high reliability and excellent resistance to environmental extremes:

- All welded construction.
- Unique uni-frame design providing high magnetic efficiency and mechanical rigidity.
- High force/mass ratios for resistance to shock and vibration.
- Advanced cleaning techniques provide maximum assurance of internal cleanliness.
- Precious metal alloy contact material with gold plating assures excellent high current and dry circuit switching capabilities.

The Series 114D and 114DD relays have internal discrete silicon diodes for coil suppression and polarity reversal protection.

By virtue of its inherently low intercontact capacitance and contact circuit losses, the 114 relay has proven to be an excellent ultraminiature RF switch for frequency ranges well into the UHF spectrum. A typical RF application for the 114 relay is in handheld radio transceivers, wherein the combined features of good RF performance, small size, low coil power dissipation and high reliability make it a preferred method of Transmit-Receive switching (see Figure 1).

**ENVIRONMENTAL AND  
PHYSICAL SPECIFICATIONS**

<b>Temperature</b> (Ambient)	-65°C to +125°C
<b>Vibration</b> (General Note 1)	30 g's to 3000 Hz
<b>Shock</b> (General Note 1)	75 g's, 6 msec, half-sine
<b>Acceleration</b>	50 g's
<b>Enclosure</b>	Hermetically sealed
<b>Weight</b>	0.09 oz. (2.55g) max.

**SERIES 114**

**GENERAL ELECTRICAL SPECIFICATIONS (-65°C to +125°C unless otherwise noted) (Notes 2 & 3)**

<b>Contact Arrangement</b>	2 Form C (DPDT)	
<b>Rated Duty</b>	Continuous	
<b>Contact Resistance</b>	0.1 ohm max. before life; 0.2 ohm max. after life at 1A/28Vdc (measured 1/8" from header)	
<b>Contact Load Ratings (DC)</b> (See Fig. 2 for other DC resistive voltage/current ratings)	Resistive: 1 Amp/28Vdc Inductive: 200 mA/28Vdc (320 mH) Lamp: 100 mA/28Vdc Low Level: 10 to 50 µA/10 to 50mV	
<b>Contact Load Ratings (AC)</b>	Resistive: 250 mA/115Vac, 60 and 400 Hz (Case not grounded) 100 mA/115Vac, 60 and 400 Hz (Case grounded)	
<b>Contact Life Ratings</b>	10,000,000 cycles (typical) at low level 1,000,000 cycles (typical) at 0.5A/28Vdc resistive 100,000 cycles min. at all other loads specified above	
<b>Contact Overload Rating</b>	2A/28Vdc Resistive (100 cycles min.)	
<b>Contact Carry Rating</b>	Contact factory	
<b>Operate Time</b>	2.0 msec max. at nominal rated coil voltage	
<b>Release Time</b>	114 Series: 1.5 msec max. 114D, 114DD Series: 4.0 msec max.	
<b>Contact Bounce</b>	1.5 msec max.	
<b>Intercontact Capacitance</b>	0.4 pf typical	
<b>Insulation Resistance</b>	10,000 megohms min. between mutually isolated terminals	
<b>Dielectric Strength</b>	Atmospheric pressure: 500 Vrms/60Hz	70,000 ft.: 125 Vrms/60Hz
<b>Negative Coil Transient (Vdc)</b>	114D, 114DD	1.0 max
<b>Diode P.I.V. (Vdc)</b>	114D, 114DD	100 min.

**DETAILED ELECTRICAL SPECIFICATIONS (-65°C to +125°C unless otherwise noted) (Note 3)**

	BASE PART NUMBERS (See Note 8 for full P/N example)	➔	114-5	114-6	114-9	114-12	114-18	114-26
			114D-5 114DD-5	114D-6 114DD-6	114D-9 114DD-9	114D-12 114DD-12	114D-18 114DD-18	114D-26 114DD-26
<b>Coil Voltage (Vdc)</b>	Nom.		5.0	6.0	9.0	12.0	18.0	26.5
	Max.		5.8	8.0	12.0	16.0	24.0	32.0
<b>Coil Resistance (Ohms ±10% @25°C)</b>	114, 114D		50	98	220	390	880	1560
	114DD (Note 4)		39	78	220	390	880	1560
<b>Coil Current (mA dc @25°C) (114DD Series)</b>	Min.		93.2	58.3	33.0	25.6	17.5	14.8
	Max.		128.2	78.3	42.9	32.8	22.1	18.5
<b>Pick-up Voltage (Vdc, Max.)</b>	114, 114D		3.5	4.5	6.8	9.0	13.5	18.0
	114DD		4.0	5.0	7.8	10.0	14.5	19.0
<b>Drop-out Voltage (Vdc)</b>	114, 114D	Min.	0.14	0.18	0.35	0.41	0.59	0.89
		Max.	2.3	3.2	4.9	6.5	10.0	13.0
	114DD	Min.	0.6	0.7	0.8	0.9	1.1	1.4
		Max.	2.8	3.4	5.3	6.5	10.0	13.0

**PERFORMANCE CURVES (NOTE 2)**

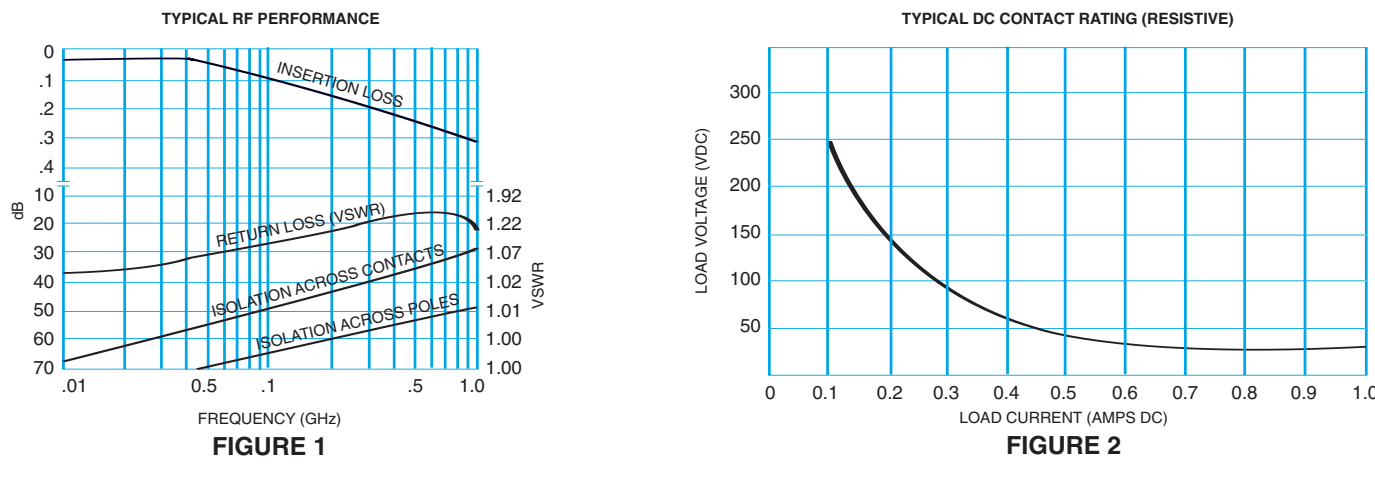

# SERIES 114

## OUTLINE DIMENSIONS

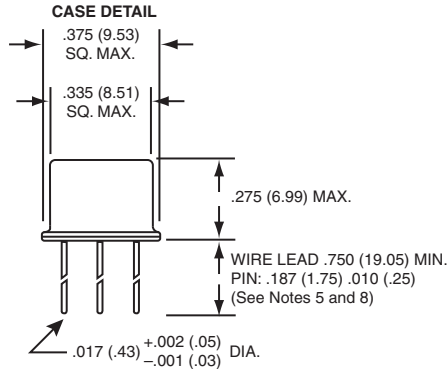

## TERMINAL LOCATIONS

(Viewed from Terminals; Numbers for Reference Only)

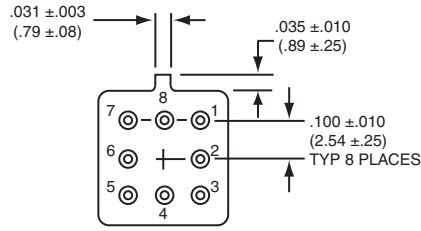

DIMENSIONS ARE SHOWN IN INCHES (MILLIMETERS)

## SCHEMATIC DIAGRAMS

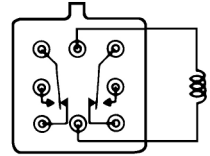

114

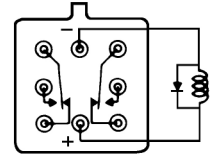

114D

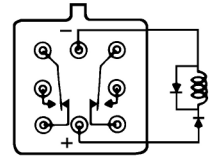

114DD

SCHEMATICS ARE VIEWED FROM TERMINALS

## GENERAL NOTES

1. Relay contacts will exhibit no chatter in excess of 10  $\mu$ sec or transfer in excess of 1  $\mu$ sec.
2. "Typical" characteristics are based on available data and are best estimates. No on-going verification tests are performed.
3. Unless otherwise specified, parameters are initial values.
4. For reference only. Coil resistance not directly measurable at relay terminals due to internal series diode. 114DD only.
5. Unless otherwise specified, relays will be supplied with either gold-plated or solder-coated leads.
6. The slash and characters appearing after the slash are not marked on the relay.
7. Screened HI-REL versions available. Contact factory.
- 8.

## Teledyne Part Numbering System for $T^2R^{\circledR}$ Established Reliability Relay

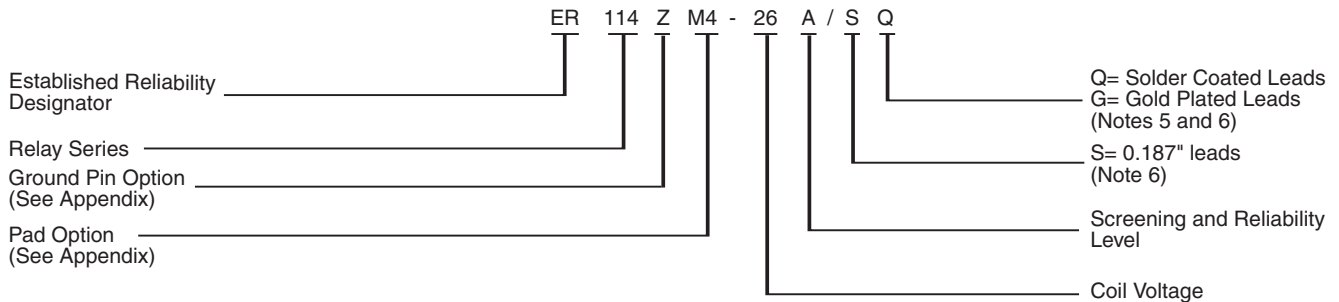

## Teledyne Part Numbering System for Military Qualified (JAN) Relays

